



# Safety Engineering & Risk Analysis Division



## Newsletter

3<sup>rd</sup> Quarter 2008

### GENERAL DIVISION NEWS

#### Let's Be a Voice for a Less Risky World

By way of introducing myself as your current SERAD chair, I would like to briefly tell you my thoughts on how I think we can grow professionally this year. ASME has been an important professional activity for me throughout my career. I received my BSME from Ohio Northern University in Ada, Ohio in 1970. In my senior year, I participated in an ASME Student Design competition and my presentation won at the area level. That experience in presenting research results was a key factor in my being hired for my first job out of college. Growing as an effective engineering communicator has continued to be a vital part of my ME career.

As the 2008-09 chair of the SERAD Executive Committee I will be making good safety and risk communication the special theme for my tenure. SERAD and its members should be speaking and writing powerfully to convince others of the value of avoiding injury and loss. I have three specific communication goals that I would like to accomplish as SERAD chair. First, I want to see to it that the Division maintains and improves its newsletter and website media. You can help by volunteering to work on the SERAD website and by sending safety and risk material to the newsletter editor. My second goal is to form a committee to evaluate the possibility for SERAD to run a one-day Professional Development Seminar. Other ASME divisions and regions hold such seminars and we should be making an effort to educate engineers about safety and risk assessment techniques. And my third goal is to develop a SERAD-sponsored ASME Policy statement on Prevention through Design (PtD). ASME is a respected, high-profile technical society. A Policy Statement that encourages universities and employers to focus on PtD would be accomplishing an important ASME mission.

I will be reporting on progress toward meeting these goals in future newsletters. I will be glad to discuss further with you how you can get involved with working on any of these goals. I look forward to collaborating with the SERAD Executive Committee and with SERAD members in making our voices heard as advocates for a safer, less risky world.

*John Etherton*

SERAD EC Chair, July 1, 2008 – June 30, 2009

### UPCOMING EVENTS

#### IMECE 2009

IMECE 2009 is nearly here! OK, maybe not exactly. However, it is not too soon to begin thinking about next year's program in Lake Buena Vista, Florida. Specifically, the abstract submittal deadline isn't too far away (March 2, 2009), so be thinking now about topics you might want to submit for publication. Also, SERAD Technical Program Coordinators can always use assistance, particularly in the area of technical paper peer reviews.

If you are interested in volunteering for this, or any other role, please contact the IMECE 2009 Technical Program Representative, or any of the SERAD Executive Committee members listed at the end of this newsletter. While specific session topics will be worked out over the coming months, the SERAD program at IMECE 2009 will again focus generally on the following core areas of SERAD: **Safety Engineering, Risk Analysis, Reliability Methods, Product and Process Safety.**

### TECHNICAL CORNER

#### Fire Investigations: Why Motorcoaches May Burn (A Mechanical Analysis)

Copyright © 2007 by Christopher W. Ferrone  
Reprinted with Author's Permission

Article Submitted By: Christopher W. Ferrone  
ARCCA, Inc.  
Chicago, IL  
Cell: 773.858.4941 / Tel: 312.676.2960  
Email: cferrone@arcca.com

#### ABSTRACT

In the wake of the Wilmer, Texas fire, which occurred during the Hurricane Rita evacuation, motorcoach fires have come to the forefront of the media. Are motorcoaches catching on fire now more than before? What could possibly explain such a phenomenon?

The purpose of this paper, through mechanical analysis and accident reconstruction, is to inform operators of the fire hazards

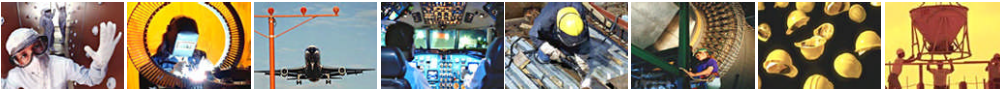

which may be present on a typical motorcoach, transit or school bus.

Once the potential hazards are identified, the individual components' care and maintenance can be monitored to prevent or limit the occurrence of a fire. The express purpose of this effort is to minimize fires on such passenger vehicles.

### INTRODUCTION

Motorcoaches are expensive and carry valuable cargo – people. Motorcoaches must be understood and maintained with fire prevention in mind.

A fire can occur on a motorcoach, transit or school bus for a variety of reasons. Unlike an automobile or even a large truck, a motorcoach is a more sophisticated vehicle with more systems and even greater complexity [1]. The author has investigated motorcoach fires for more than 20 years. However, as a result of the fire in Wilmer Texas, it was decided that this analytical process should be written to assist operators in the prevention of future fires.

During the past two decades the author has investigated numerous motorcoach fires. While analyzing the cause and origin of these fires, a collection of data has shown a consistent pattern.

As simple as it appears, if the vehicle is in motion certain items are valid as possible causes. Likewise, if the vehicle is stationary with the engine on or off other items become potential causes. In either case, the situation is dangerous and costly in both human life and property (Photo 1).



Photo 1: Motorcoach involved in fire during Hurricane Rita evacuation (September 24th 2005)

The more common causes discussed here are not ranked in order of likelihood. The operational profile and vehicle history can help determine which of these trouble spots need attention first. Items to be discussed in this paper are:

- alternator(s)
- starter
- fuel/combustible materials/lubricants
- hubs/bearings
- brakes (drum & disc)
- tires
- turbochargers
- sensors
- auxiliary heaters (diesel furnace)
- 2007 emission schemes

### WHAT IS REQUIRED FOR A FIRE

Three elements are needed to create a fire: air, a combustible material and an ignition source. These three items form what is known as the Fire Triangle (Fig. 1); if any one of the three elements of the triangle is not present a fire cannot occur despite the presence of the other two.

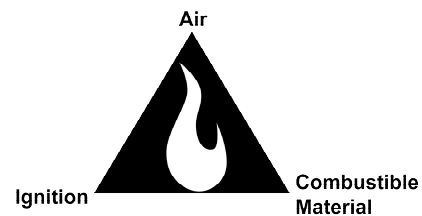

Fig. 1: Fire Triangle

Air is all around us; making for an abundant supply of the first element. A combustible material, the second element, is any thing that may be present on the motorcoach such as diesel fuel, power steering fluid, engine oil, transmission fluid, gear/hub oil and grease to name a few. The third element, the ignition source, can come in many forms. An open flame, a sustained duration spark and auto-ignition are the most common ignition sources. Along with the completion of the fire triangle, atomization of the liquid must occur in order to satisfy the stoichiometric requirements (14:1) to burn. Absent this proper air-to-fuel ratio, the substance is deemed too rich to burn and will not ignite.

The atomization increases the surface area of the liquid by creating small spheres or droplets. By taking a cube of one cubic inch in volume and simply dividing it up into five equal spheres, each 1/5 of 1 cubic inch, the total surface area of the five spheres is 37% more than the surface area of the original same volume of one cubic inch (Fig. 2).

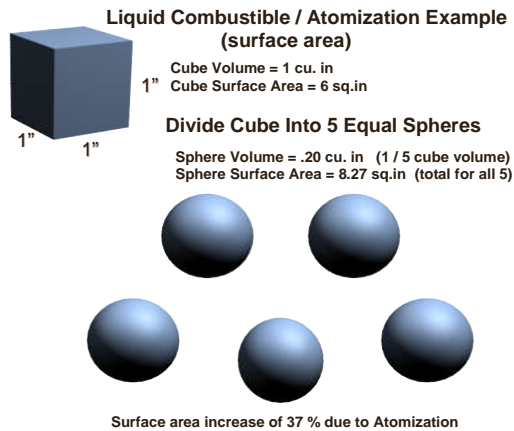
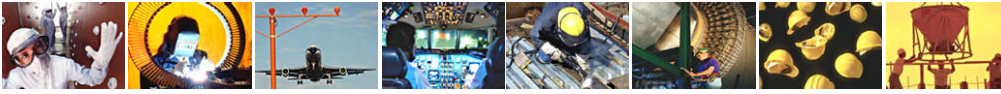

Fig. 2

This increase in surface area is what allows the air to properly mix with the liquid for the stoichiometric ratio to be satisfied. As an example, this atomization usually comes from a spraying of the liquid from a pressurized pinhole leak in a hose or component housing. Once this ratio has been met a fire can occur.

**Temperature Mapping:** Temperature mapping is a technique used to determine the surface temperature of various components on the motorcoach. By using a non-contact laser thermometer, a map of component surface temperatures can be established for any particular vehicle. For this study an MCI DL-3 was used (Photo 2).



Photo 2: MCI DL-3

The purpose of such a study is to verify individual component temperatures to assist in the cause and origin analysis, as well as fire prevention. A sample of surface temperatures has been provided in Appendix A. As you can see from this, certain components are normally at the auto-ignition temperature of the

on-board fluids and some are not. What can be taken from this is that if the “cooler” components are functioning normally, they cannot be an auto-ignition source. If a fire was to be traced back to a “cooler” component, such as a drive axle hub, that would indicate that this component experienced some type of mechanical failure which preceded the fire and became the triggering element – the ignition source. In summary these “cool” components cannot become an ignition source without experiencing a localized failure due to the fact that their normal operating (surface temperature) is less than the average (on board fluid) auto-ignition temperature.

**IGNITION SOURCE**

**Alternator:** Most motorcoaches use either a large oil cooled gear/belt driven alternator or a more conventional style alternator similar to an automotive application; but larger. The typical varieties are a Delco 50-DN (Photo 3a) or an air cooled dual Bosch T1 (Photo 3b) configuration. The author must stress that these manufacturers are not being singled out for any particular reason; however, they are the most commonly found units within this type of vehicle. For most applications, the charging system for the motorcoach produces 275 amperes or more – as much amperage as a typical single family home may have. With this, the alternator (and system) carries great potential as an ignition source.

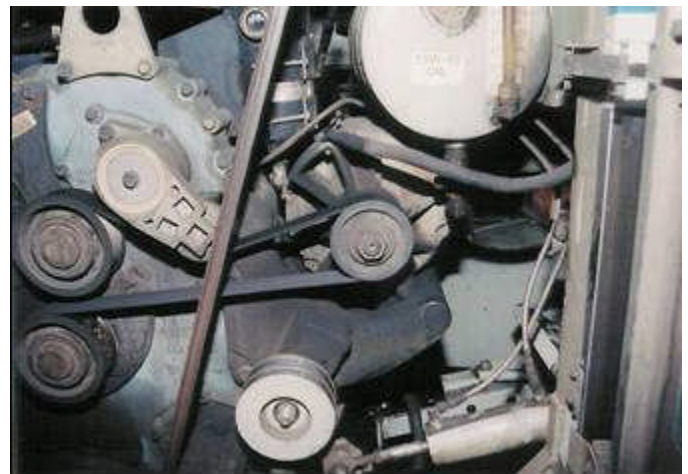

Photo 3a: 50-DN, Series 60

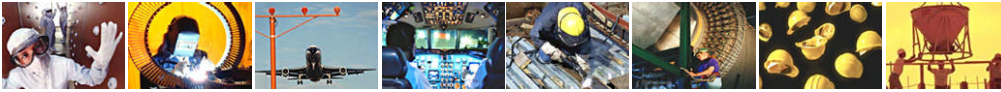

Photo 3b: Bosch T1, Series 60



Photo 3c: 50-DN, Series 92

Typically with a 50-DN installation (Photos 3a & 3c), the B+ (direct battery feed) cable is routed to a large stud on the back of the alternator. This in turn is held in place with a nut (to the stud) along with various clamping methods to secure the cable end from any movement (Photo 4).

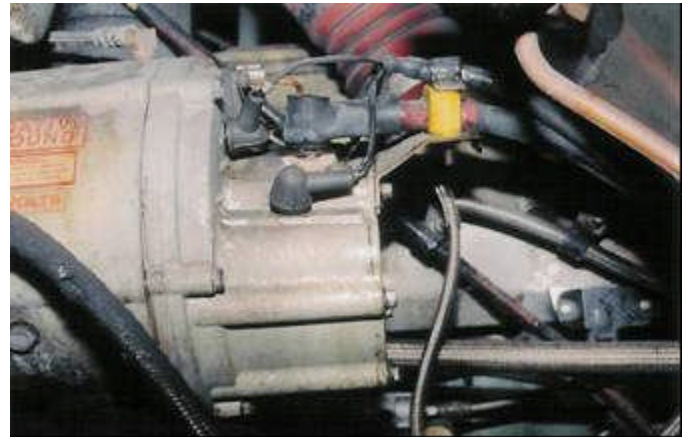

Photo 4: 50-DN, Series 60, MCI Installation

These connections must be quality checked after the alternator has been installed and inspected periodically as well as to ensure there is no movement. It is noteworthy to point out that with some applications, these cables may need to be temporarily removed to facilitate other non-alternator related repairs. The same care and vigilance should be used whether alternator or other repairs are being made. If the B+ cable is loose, it can, by its own weight either fail the plastic insulator material surrounding the stud at its base, internal to the alternator, or wear through the cable insulation locally and make unwanted contact with the support bracket. When this occurs the cable can act similarly to an arc welding machine and cut its way through the bracket (Photo 5).



Photo 5: 50-DN, B+ Bracket, Series 60

Once the B+ cable end is free, the cable can drop, making contact with a ground source, resulting in a sustained duration spark. This is exceptionally critical in that with some engine applications the alternator is installed above and on the fuel side of the engine.

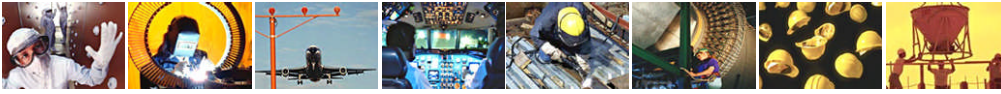

In addition to the cable and its mounting system there is another potential fire hazard. When installing the B+ cable to the stud (50-DN) the proper torque must be used to ensure that the plastic material (internal insulator) is not broken or compromised in any way (Photo 6a). If this nut is over-torqued, or otherwise installed incorrectly, it could lead to a loose stud subsequently leading to an ignition source and fire (Photo 6b).

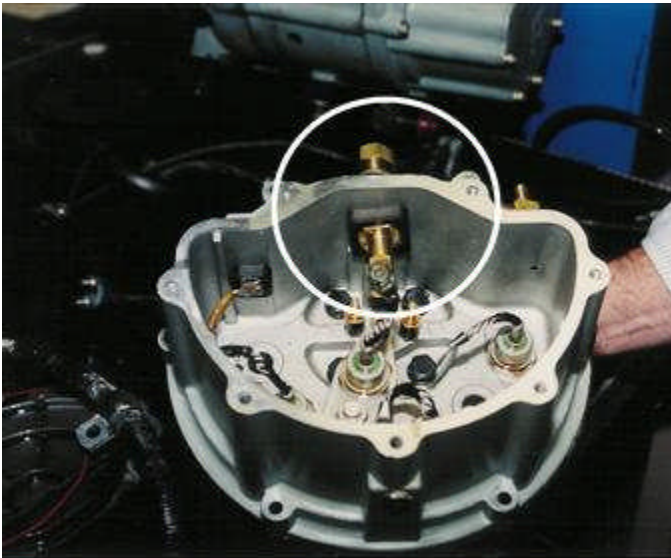

Photo 6a: 50-DN, B+ Stud Insulator



Photo 6b: 50-DN, Result of Failed B+ Stud Insulator

In some instances a fire has begun with the vehicles' engine off and after some period of time since the most recent engine shut-down. This can be attributed to an internal alternator failure;

specifically a diode failure. Diodes act as a one-way check valve for current. Typically, if a diode fails in this scenario, positive (B+) battery voltages goes to ground and has been known to start a fire. The solution to this potential fire scenario is to park the motorcoach with the main battery switch off. This will disconnect the batteries from the alternator eliminating this potential.

**Remote Jump Post:** With some applications a convenience feature is provided in the engine compartment for "jumping" a disabled vehicle. This is typically a positive (+) cable running from the starter to an exposed stud. These connections must be inspected and maintained to provide integrity. Additionally, this stud is covered with a flexible rubber boot (Photo 7).



Photo 7: Remote Jump Post

This boot must be in good condition and over the positive (+) stud at all times. A loose jumping stud/cable can create a sustained duration spark similar to the alternator B+ cable.

**Starter:** Most motorcoaches use either a Delco 42MT or 50MT starter. Under normal circumstances the starter draws 800 to 1000 amps respectively while cranking the engine. When it is not cranking the engine (no current flow) it is simply exposed to battery voltage. As with the alternator, the starter is connected to the batteries via a B+ (direct battery feed) cable. It too is routed to a stud on the starter motor. However, this is initially routed to a bulkhead junction (Fig. 3; Photos 8a & 8b); again this is a heavy cable and must be properly connected and supported in its mounting.

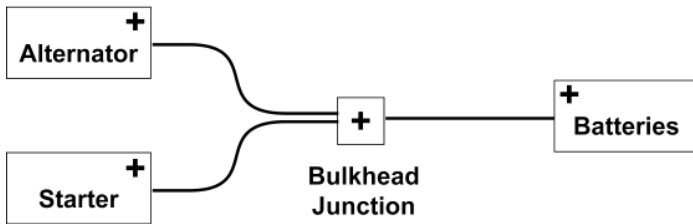
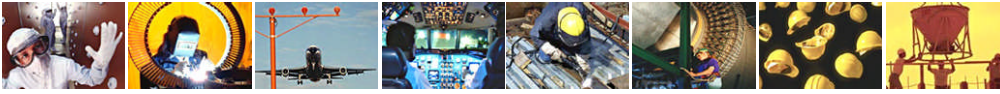

Fig. 3



Photo 8a: Bulkhead Connection 50-DN



Photo 8b: Bulkhead Connection Bosch T1

Care must be given to the cable condition, cable to starter connections, as well as its' routing so that this B+ cable is not making unwanted contact and potentially coming in contact with ground as a result of an insulation breach.

The starter should be treated and cared for in the same manner as the alternator since they both reside on the fuel side of the engine in some applications.

**Combustible Materials:** In some remote cases, the onboard fuel supply can be a causal element in a fire. In order for the fuel to ignite, the surface temperature of the engine and related components must be at least at the auto-ignition temperature of diesel fuel. All of the liquids; fuel, power steering fluid, engine oil and hub/gear oil, found on the motorcoach have an auto-ignition temperature (see appendix B). If one or more of these fluids were to come in contact with a sufficiently hot surface at auto-ignition temperature; that fluid would ignite in the absence of an open flame. To minimize fluid fires, all hoses, housings, couplings, fittings and filters must be inspected diligently to reduce or eliminate leaks which could lead to a fire. Practically speaking, the first step is to regularly clean the engine, transmission and interior surfaces of the engine compartment. This has a triple advantage to the operator. First, oil and road dirt covering the engine will act to insulate it holding in engine heat. Second, when the engine is clean it is easier to locate a fluid leak. Lastly, with a clean engine, you reduce the risk of fire and it spreading by virtue of not having any combustible materials on the engine itself.

**Hub Failure:** Wheel hubs low on oil can have an elevated operating temperature high enough to ignite the surrounding combustible materials by auto-ignition. Coincident to this, in some cases, is a wheel end failure resulting in a "wheel-off" situation [2]. Typically, the outer wheel bearings' lowest point is above the lowest point of the hub seal. Therefore, since the outer bearing is at that elevation, it starves for oil first. The inner bearing is at a lower point in the hub and is usually bathed in oil for a longer period of time. There are two common failure modes for the hub (non-driving) to be low on oil; hubcap failure and seal failure. The hubcap can have at least four failure modes; the plastic site glass, o-ring, the rubber plug and the mounting gasket. For any of these reasons the hub can become low on oil. As for a drive hub, the axle flange gasket or seal can be a leak point allowing the hub to become low on oil. It is noteworthy to mention that when the seal wiper becomes worn (grooved) it may create a leak point despite the integrity of the seal itself. The wiper should be inspected each time the hub is removed and changed if it appears to be excessively worn. In some cases, during a wheel bearing failure, the vehicles' A.B.S. dash light may become illuminated as a result of the sensor-to-hub gap becoming greater due to the hub beginning to come off of the spindle or axle tube or from a skidding or locked tire/wheel.

An additional risk exists, with disc brake applications, during a wheel bearing/hub failure. That is, as the outer bearing begins to fail, the hub load is transferred from the outer bearing to the brake caliper, brake pads and rotor. Once the outer bearing has failed completely, no longer able to support the hub load, the

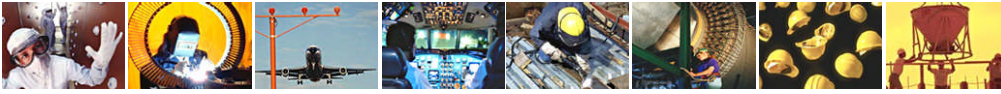

caliper, brake pads and rotor are then supporting that particular wheel end (Photos 9 & 10).



Photo 9: Disc Brake (RH Tag Axle) [Involved]



Photo 10: Disc Brake (LH Tag Axle) [Not Involved]

This is due to the fact that the caliper rides in the caliper carrier which is attached to the spider which is mounted to the axle tube/spindle (Fig. 4).

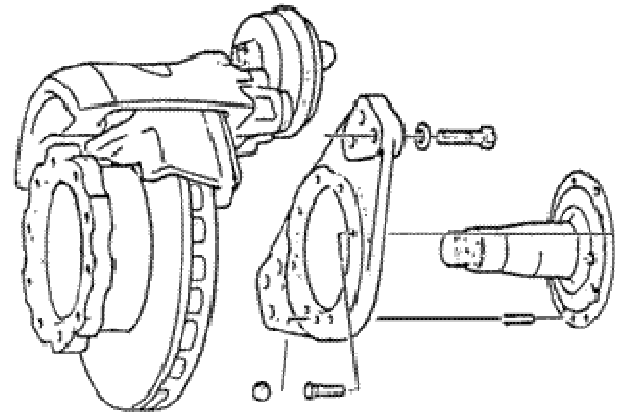

Fig. 4: Disc Brake, Caliper, Spider & Spindle

Once the brake caliper begins carrying the load, at that particular wheel end, the surface temperature of the brake pads and rotor (or drum) rise well above the auto-ignition temperature of the surrounding combustibles (due to friction) and eventually igniting them. The combustible material typically ignited by this failure mode is the tire(s). Tires generally revert (melt) at approximately 250°F and catch fire over the 600°F mark. It is common, although not mandatory, for the tire fire to occur when the vehicle comes to a stop. This is the condition with the least amount of air flow circulating around the brake rotors, brake drums and tires. Without air flow around these items, their temperature rises rapidly and is transmitted to the tire—subsequently igniting it. This concept of brake caliper/pad/rotor supporting the hub load can typically be seen by a thinner more worn outside brake pad as compared to the inner pad. This is due to the hub moving outward, away from the spindle. As a result of this temporary load support from the caliper, the operator may continue to drive the vehicle without any indication of a problem until it is too late.

**Disc Brakes:** A “frozen” disc brake caliper can generate enough heat to ignite the surrounding combustible materials and sustain a fire. Proper inspection and lubrication intervals should be adhered to along with a periodic activation and release sequence confirming that the calipers are releasing and allowing the rotor to turn freely. This scenario applies to both air and hydraulic disc brakes. A simple method to determine the proper action of the calipers is to insert a feeler gauge (.002” - .004”) between the brake pad and rotor. By applying the service brakes a technician can feel if the gauge goes into this space, remains there upon brake application and is then released upon release of the service brakes. In some early applications, Rockwell disc brakes were used which in some instances were not supplied with grease fittings in the calipers (Photo 11, Fig. 5). This very point leads to a “frozen” caliper scenario which, in the author’s direct experience, results in a fire at that wheel end.

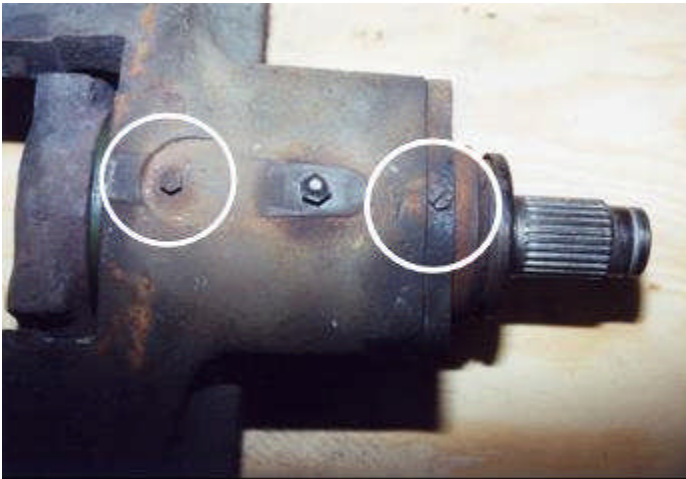
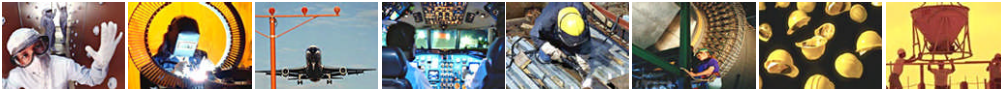

Photo 11: Rockwell Caliper ADB-1560

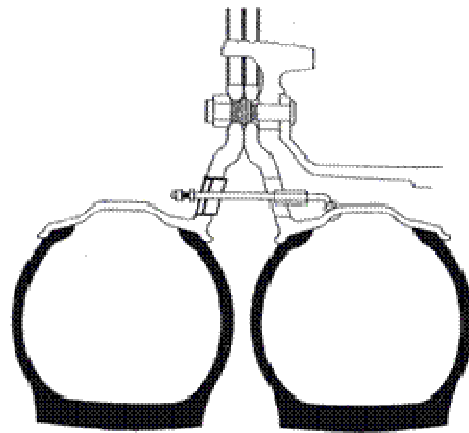

Fig. 6: Cross Section View of Dual Tires

If the adjacent tire is under-inflated the gap closes and the tires begin to “kiss”. Since an under-inflated tire only bulges at the road surface, a cyclical contact event occurs between the inflated tire and the under-inflated tire. Over time this cyclical contact may generate heat increasing the tires temperature. Therefore, operators should always ensure that all tires, especially dual tires, are inflated and not in contact with one another. In general, operating temperatures for radial tires can be anywhere between ambient plus 60°F (150°-180°F). Under severe conditions the operating temperatures will range in the 200°F areas [3].

**Turbocharger:** Turbochargers are a dual threat as an ignition component. First, since they are typically very hot, on the surface, they can act as an auto-ignition source. Second, upon their own internal failure, they can become an ignition source by virtue of their own internal lubrication oil. The typical turbocharger supports the shaft of the compressor and turbine with a non-conventional bearing. This is unlike the typical roller bearing. Instead the shaft is supported by two bearing collars which are supported by the boundary lubrication layer (Fig. 7).

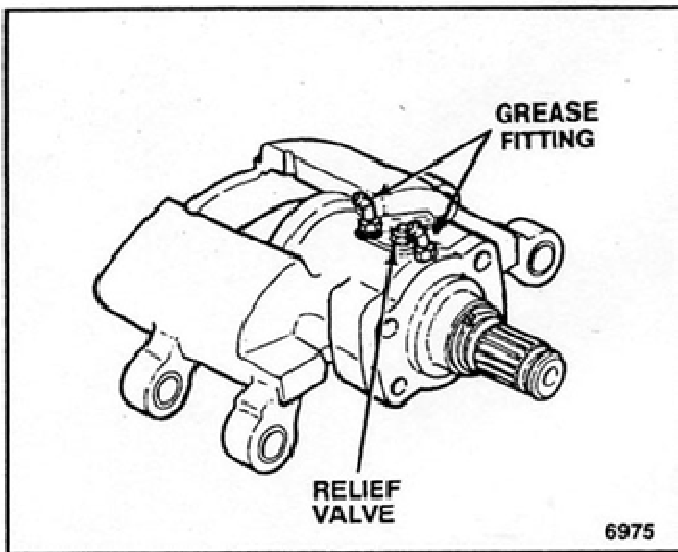
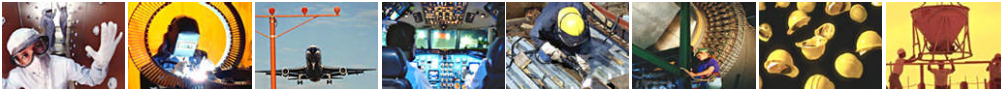

Fig. 5: Rockwell Caliper ADB-1560

**Tires:** A flat or under-inflated dual tire can become a fire hazard and in some cases go undetected. Dual tires are spaced apart to provide a gap (Fig. 6).





Specifically, blue smoke, due to oil consumption along with reduced engine torque will be noticed. Also a specific oil leak, from the waste gate pivot point, can be observed (Photo 14). Once oil has begun to leak from this point on the turbocharger it should be removed from service and the exhaust system should be thoroughly cleaned. To assist in preventing this failure mode; the turbocharger waste gate or variable geometry function (V.G.T.) must be confirmed. Additionally, the shaft free play, both axially and radially, must be inspected by a mechanic.



Photo 14: Waste Gate Pivot, Series 60

To confirm the function of the waste gate (Photo 15), apply regulated air pressure to the boost line (20-30 psi) to exercise the waste gate slave cylinder. To confirm the V.G.T. function (Photo 16), turn on the vehicles' ignition to "on" and observe the slave cylinder motion.



Photo 15: Waste Gate, Series 60

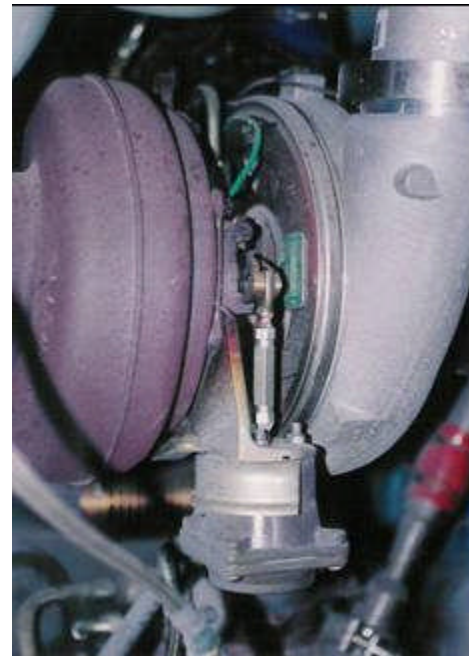
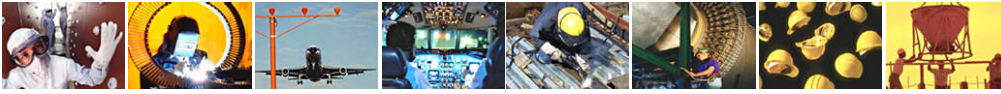

Photo 16: V.G.T., Series 60

If there is no motion for either system upon these diagnostic tests, they are defective and must be replaced/repared. These two systems regulate turbocharger boost pressure. If they were to fail to regulate this pressure, it may lead to an internal failure thus leading to a fire.



**External Turbocharger Oil Lines:** With the Detroit Diesel Series 92 application, there is only one external oil line. The oil supply line is positioned on top of the turbocharger and must be inspected periodically for leaks (Photo 17).

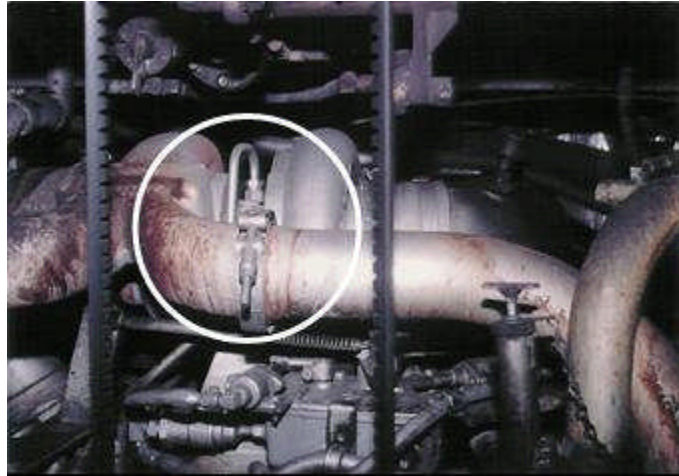

Photo 17: Turbocharger Oil Inlet Line, Series 92

With most 4-stroke inline engine applications, the turbocharger has two oil lines which need to be periodically inspected (Photo 18). These turbochargers have an external supply and return oil line. In either case, a leaking oil line must be repaired to prevent an auto-ignition fire.

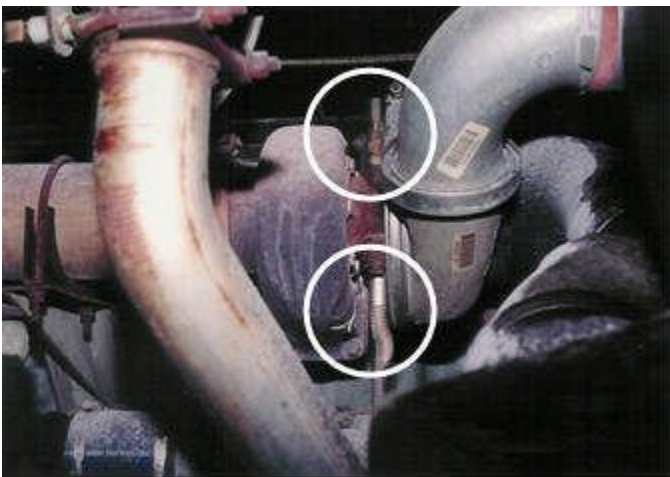

Photo 18: Turbocharger Oil Inlet Line, Series 60

**Sensors:** In most applications there are sensors which are exposed to either fuel, engine oil, transmission fluid and hydraulic oil, to name a few. These sensors are typically diaphragm type; that is to say, an internal diaphragm is moved by the fluid pressure inside the sensor/switch. Since pressurized fluid enters these sensors/switches it is vital that they be periodically inspected for leaks. Based on their position on the

engine/transmission they may become a source for a combustible material which may come in contact with an ignition source and initiate a fire.

**Auxiliary Heaters:** Also known as diesel furnaces, auxiliary heaters heat the onboard coolant when the engine is not running. However since it is a furnace which burns diesel as fuel it must be periodically inspected for function, control and integrity. Specifically, its cycle time and control must be verified to assure it is functioning when it should be, as well as, turning off when commanded. Additionally, the fuel lines must be inspected to confirm there are no leaks. In fact, in the summer months it is good practice to disconnect the heater function power supply and loop the supply and return fuel lines together (Photo 19).

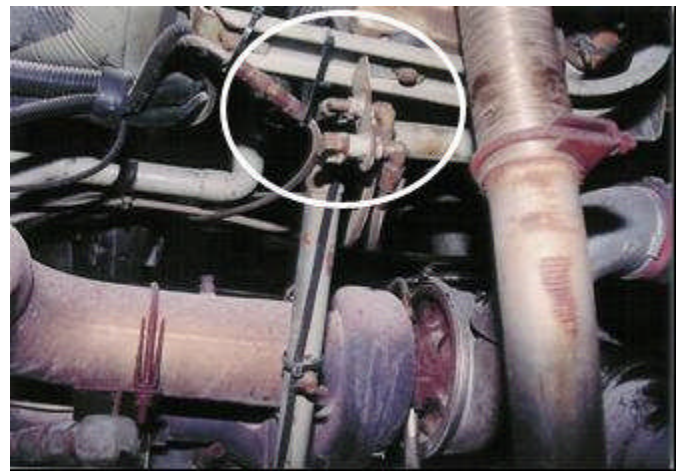

Photo 19: Looped Fuel Lines, Auxiliary Heater

This will assure that fuel does not leak from the furnace itself when not in service. It should be pointed out that the heaters' exhaust pipe (Photo 20), within minutes of heater activation, reaches 375°F and continues to climb approaching the auto-ignition temperature of most of the vehicles fluids.

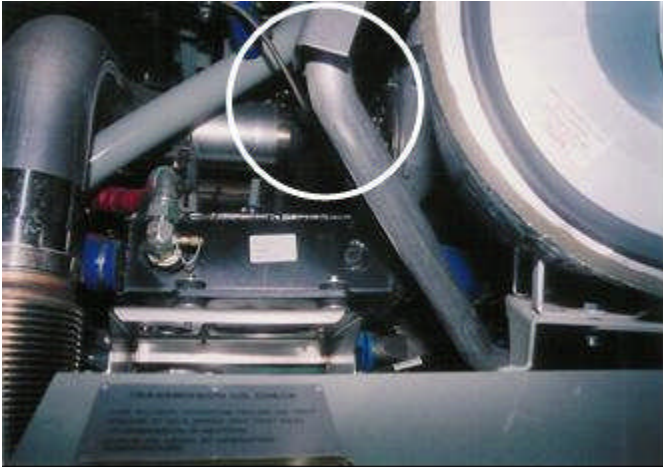
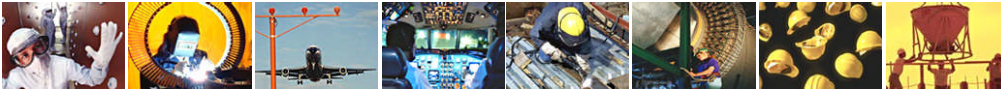

Photo 20: Auxiliary Heater Exhaust Pipe

Therefore, it is vital that any leak, of any fluid in this area, be immediately repaired to minimize high temperature contact and subsequent fire.

**2007 Emissions Schemes:** At the time of this publication, very few 2007 engines with regeneration capability are in the stream of commerce. However, the design suggests regenerating (cleaning) the particulate trap by elevating its temperature to burn off the material trapped inside. [5] In order to do this the engine must create exhaust gases with high enough temperatures to complete this process. In some designs, during regeneration, raw fuel is injected near the turbocharger, via a doser, increasing the temperature of the exhaust gases to 1200° F. As with any other component, with a high (>430° F) surface temperature, leaks in the immediate area must be repaired to avoid contact with this system while it is regenerating the particulate trap. Lastly, this systems' interlocks, which dictate when it can function, must be confirmed to be working to avoid a cycle of regeneration at a time or location which is undesirable.

**Additional Ignition Sources:** Additional body related ignition sources are:

- evaporator motor(s)
- condenser motor(s)
- defroster motor(s)
- A/C compressor clutch coil/wires
- VCR systems
- P.A. systems/ radio
- G.P.S. systems

These systems must be inspected periodically for proper wire/cable routing and support along with proper ground connections and insulation. Usually not a leading fire cause, they must be as vigilantly inspected as any other component on the vehicle.

## CONCLUDING REMARKS

The purpose of this paper is to bring to the attention of manufacturers, owners, operators and mechanics that methods are available which can mitigate this type of accident. An inspection list has been provided (see Appendix C) to further assist the reader in preventing motorcoach fires. This list of items can be included in a Preventative, Periodic and Annual Maintenance Inspection Program. Additionally, some of the inspection items may be incorporated into a daily driver (pre/post trip) inspection.

Furthermore, it is to assist the investigator in conducting fire cause and origin analysis of motorcoaches, transit and school buses involved in this type of occurrence as well as to show the mechanical finger prints which are associated with it.

## REFERENCES

- 1). Ferrone, C.W., "Only You Can Prevent Motorcoach Fires," Bus Ride Magazine, August, 2005.
- 2). Ferrone, C.W., "Hub Maintenance Ensures Hub Retention," Bus Ride Magazine, November, 2005
- 3). Bridgestone Commercial Tires (Tire, M.D.)
- 4). Detroit Diesel Corporation; S-60 Burst Logic Safety Recall, NHTSA-06E-019, DDC: 06C-4.
- 5). Detroit Diesel Corporation; "Introducing the New 2007 Series 60"; brochure and DVD, PT1M, 6SA2000 (0604), PT3M, 6SA2004 (0603).

## APPENDIX A

### Surface Temperatures in F°/C° @ Ambient Temperature (85F°)

• Disc Brake Rotor	420° / 215°	MCI DL-3
• Drive Axle Hub	150° / 65°	MCI DL-3
• Steering Axle Hub	137° / 58°	MCI DL-3
• Tag Axle Hub	166° / 74°	MCI DL-3
• Turbocharger [hot]	607° / 319°	DDC S-60
• Turbocharger [cold]	198° / 92°	DDC S-60
• Exhaust Manifold	390° / 198°	DDC S-60
• Exhaust at Turbocharger Inlet	585° / 307°	DDC S-60
• EGR	261° / 127°	DDC S-60
• Engine Block [side]	232° / 111°	DDC S-60
• Transmission Housing	198° / 92°	Allison B-500

Note: These are examples only and are not meant to represent all temperatures found on a motorcoach, transit or school bus.

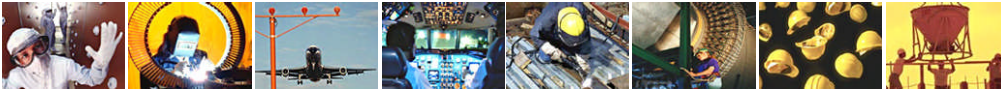

## APPENDIX B

### On Board Fluids - Auto-Ignition Temperatures in F°/C°

• Diesel Fuel	446° / 230°
• Power Steering	417° / 213°
• Engine Oil	449° / 231°
• Transmission Fluid	417° / 213°
• Coolant (50/50)	903° / 483°
• Hub/Gear Oil	428° / 220°
• Tires (smoldering)	450-500° / 232°-260°

Note: These are examples only and are not meant to represent all types and varieties of fluids found on a motorcoach, transit or school bus.

## APPENDIX C

### Preventative, Periodic, Annual and Daily (Pre/Post Trip) Maintenance and Inspection Items

- B+ Cable at alternator secure (stud, bracket and clamps in position)
- Alternator oil lines and rear cover plate secure and not leaking
- All alternator electrical studs covered with rubber boots
- Remote Jump Post secure and stud covered with rubber boot
- Starter cables secure and routed properly
- Bulkhead connection for B+ cables (starter and alternator) secure
- Engine compartment clean/dry of fluids
- Engine and Transmission fluid connections/hoses secure and not leaking; sensors not leaking
- No leaks dripping onto pavement
- Hub-Caps; no visible leaks, rubber plug in place, sight glass is clear, oil at proper level
- Oil seals are in good condition, no leaks (only observable from under vehicle)
- Disc brake rotors (if visible) clean with no bluing
- Dual tires not making contact with each other
- Turbocharger oil line(s) not leaking, waste gate pivot pin not leaking oil
- Exhaust system; no oil exiting from muffler, no excessive blue smoke (turbocharger oil consumption)
- Engine has appropriate performance (torque)
- Auxiliary heater not leaking fuel
- No active / Illuminated A.B.S. dash light\*

## **Envision your article here next issue!!**

For future issues, we want to hear from you! Please submit articles of technical interest to the editors for consideration for publication in this section. These articles can be examples of applications of Safety Engineering, Risk Assessment, Reliability engineering techniques in your field, or can be examples of novel approaches in these areas.

Submit your ideas and articles to either of our co-editors, Ward Baun at [ward.baun@utcpower.com](mailto:ward.baun@utcpower.com), or David Weeks at [daweeks@rmeltd.com](mailto:daweeks@rmeltd.com)

## **SERAD VOLUNTEER OPPORTUNITIES**

**SERAD Newsletter:** Assistance with all aspects of the development and publication of this newsletter. This may include review of technical articles submitted, interviewing of experts, editing articles, concept development. If interested, contact Ward Baun at (860) 727-7234 or at [ward.baun@utcpower.com](mailto:ward.baun@utcpower.com)

**SERAD Technical Paper Reviewers:** Peer review technical papers for SERAD sessions at future conferences. There are immediate needs for reviewers for abstracts / papers submitted for IMECE 2009, from March through July 2009. If you are interested, please contact one of the SERAD Executive Committee members.

**SERAD Website Maintenance:** Assistance with all aspects of maintaining the SERAD website, updating content for the website. Contact any of the SERAD Executive Committee members listed in the Contacts section of this newsletter.

## **REMINDER**

Remember that one of the benefits of being a SERAD member is the opportunity to purchase a subscription to the Elsevier journal, *Reliability Engineering and System Safety*. Normally not available to individuals, as a SERAD member, you can purchase a year-long (12 issue) subscription to this valuable journal for \$156. See the Important Website Links section below for a hyperlink to the order form on the SERAD website.

## **IMPORTANT WEBSITE LINKS**

**Elsevier Journal, "Reliability Engineering and System Safety" SERAD Member Order Form:**

<http://divisions.asme.org/serad/publications/SERADRESSformformembers07.pdf>

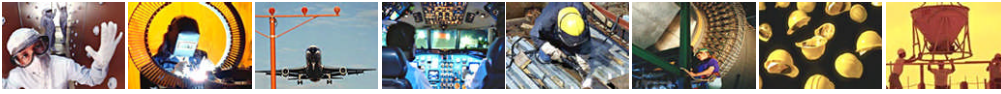

## CONTACTS

### SERAD Executive Committee

#### Chair

**Dr. John R. Etherton**  
Center for Safer Solutions  
241 Waitman St  
Morgantown WV 26501  
Cell: 304-282-0723  
[jre@saferjobs.com](mailto:jre@saferjobs.com)

#### 1<sup>st</sup> Vice Chair

**Enrique A. Susemihl**  
Senior Research Specialist  
FM Global  
1151 Boston-Providence Turnpike  
Norwood, MA 02062  
Tel: 781-255-4907  
Fax: 781-255-4024  
[enrique.susemihl@fmglobal.com](mailto:enrique.susemihl@fmglobal.com)

#### 2<sup>nd</sup> Vice Chair

**Chinh Bui, PE**  
Manager of Safety and Reliability  
Hamilton Sundstrand Company  
1 Hamilton Road, M/S 1A-2-W66  
Windsor Locks, CT 06096  
Tel: 860-654-3028  
Fax: 860-660-3051  
[chinh.bui@hs.utc.com](mailto:chinh.bui@hs.utc.com)

#### 3<sup>rd</sup> Vice Chair/Treasurer

**Dr. Curtis Lee Smith**  
Advisory Engineer  
Idaho National Laboratory  
PO Box 1625, Mail Stop 3850  
Idaho Falls, ID 83415-3850  
Tel: 208-526-9804  
Fax: 208-526-2930  
[Curtis.Smith@inl.gov](mailto:Curtis.Smith@inl.gov)

#### 4<sup>th</sup> Vice Chair/Secretary

**John W. Lyver, IV, C.S.P.**  
Manager, Nuclear Flight Safety  
Assurance  
NASA Headquarters  
Office of Safety and Mission Assurance  
Mail Stop 5V79  
300 E Street, SW  
Washington, DC 20546  
Tel: 202-358-1155  
Cell: 703-585-3477  
[jlyver@nasa.gov](mailto:jlyver@nasa.gov)

### SERAD - Other Contacts

#### Technical Program Representative IMECE 2009

**Vitali Volovoi, Ph.D**  
Georgia Institute of Technology  
School of Aerospace Engineering  
270 Ferst Drive  
Atlanta, GA 30332-0001  
Tel: 404-894-9811  
[vitali.volovoi@ae.gatech.edu](mailto:vitali.volovoi@ae.gatech.edu)

#### Student Design Contest

**Brian G. Brady**  
Roger Harvey PE PC  
25 Kinkel Street  
Westbury, NY 11590-4914  
Tel : (516) 333-2520  
Fax : (516) 333-2530  
[bgb Brady@cs.com](mailto:bgb Brady@cs.com)

#### ASME

**Thomas E. Wendt, P.E., EMCP**  
Senior Program Manager  
Global, Technical & Affinity  
Communities  
P.O. Box 044718  
Racine, WI 53404-7015 U.S.A.  
Tel: 1.262.752.9193  
Fax: 1.262.752.9195  
[wendtt@asme.org](mailto:wendtt@asme.org)

#### ASME

**Jacinta McComie-Cates**  
Administrator, K & C  
Three Park Avenue  
New York, NY 10016  
Tel: 212-591-7052  
Fax: 212-591-7671  
[mccomiej@asme.org](mailto:mccomiej@asme.org)

#### ASME – Engineering & Technology Management Group Leader

**John T. Bozewicz**  
Phone: 215-897-7603  
[bozewiczj@asme.org](mailto:bozewiczj@asme.org)

### SERAD Newsletter Committee

#### Co-Editor

**Ward O. Baun III**  
Fellow-Reliability Engineering  
UTC Power  
195 Governors Highway  
South Windsor, CT 06074  
Tel: 860-727-7234  
Fax: 860-998-9972  
[ward.baun@utcpower.com](mailto:ward.baun@utcpower.com)

#### Co-Editor

**David A. Weeks**  
P.E., DEE, CIH, QEP, MAC  
Senior Partner  
Risk Management & Engineering Ltd.  
705 W. Avenue B, Suite 400  
Garland, TX 75040  
W: (972) 272-0386  
F: (972) 272-0784  
C: (214) 762-7076  
[daweeks@rmeltd.com](mailto:daweeks@rmeltd.com)