



2008 ASME Annual Meeting – Engineer-to-Entrepreneur Session

Monday June 9, 2008 – 1:45-3:15pm
Walt Disney World Swan Resort – Orlando, FL

AudioAccess Innovation Challenge

You are part of a new start-up company called *AudioAccess, Inc.* which specializes in products using [speaker + keyword] recognition. *AudioAccess'* marketing team has collected data showing people responded favorably to speech-keyed devices from a significant customer base including college students, handicapped and older citizens, "techies", and people living in areas of the country with extreme climate (hot or cold). Note also that combination and key locks (used on lockers, bikes, etc.) have not changed in almost 100 years. Door locks have had the most radical design change with swipe card access, but many door lock designs have not changed.

Because you and your colleagues are the most creative people on staff, the *AudioAccess'* New Products Manager has formed several teams and asked each team to come up with a innovative new design that can make *AudioAccess* the market space leader for applications where controlled access or entry is a key product feature.

Good news: a small device from Sensory Inc. (<http://www.sensoryinc.com/>) can be trained to recognize a short phrase and the voice speaking the words, providing biometric security through voice. Sensory's Speaker Verification Chip (see Appendix A) offers the capability of being able to identify whether or not a password is spoken by the original individual who trained that password. For example, the Sensory Chip can differentiate between Joe Smith saying "apple-banana-orange" and George Baker saying the same phrase. The user trains 1-4 passwords (the more passwords, the better the security) that can create voice access (or denial) to any product. Equal error rates (where the probability of an incorrect acceptance equals that of an incorrect rejection) ranges between 0.01-7% depending on the number of words and whether the passwords are known to the imposter.

The New Product Manager wants product concepts before 3 p.m. today. Your team must creatively explore viable product options based on the Sensory Speaker Verification Chip by selecting market/user needs, narrowing down to one product concept, and delivering a 2 minute product concept "pitch" to the New Product Manager on why your team's concept is the best concept. Include in your pitch:

- Product name
- "Pain" that your product is solving
- Product use scenario
- Who will buy and who will use the product...they may be different!
- What current products will your solution "beat" in the market
- IP (Intellectual Property) issues
- Suggestions on funding

Assume that, in volume production, the Speaker Verification device can fit inside a volume of space of ½" x 1" x 1", including battery or mini-fuel cell, and price per device (not including power source) is \$3.00 in volume 10,000.

See Appendix A for more technical information on the Speaker Verification product (RSC-4X Family of Speech Recognition and Synthesis Microcontrollers)



Speaker Verification

Biometric security through voice

Sensory's Speaker Verification chip offers the capability of being able to identify whether or not a password is spoken by the original individual who trained that password. The user trains 1-4 passwords (the more passwords, the better the security) that can create voice access to any product. Equal error rates (where the probability of an incorrect acceptance equals that of an incorrect rejection) ranges between 0.01-7% depending on the number of words and whether the passwords are known to the imposter.

RSC-4x Family of Speech Recognition and Synthesis Microcontrollers

The RSC-4x family represents Sensory's next generation speech processors designed to bring advanced audio features to cost sensitive embedded and consumer products. Based on an 8-bit microcontroller, the RSC-4x family integrates speech-optimized digital and analog processing blocks into a single chip solution capable of accurate speech recognition as well as high quality, low data-rate compressed speech. Products can use one or all features in a single application.

The RSC-4x family supports FluentChip™ technology, which includes advanced algorithms that add features and increase accuracy. In addition to the improved recognition performance, the RSC-4x family provides further on-chip integration of features, including a microphone preamplifier, twin-DMA units, vector accelerator, hardware multiplier, 3 timers, and 4.8 Kbytes of RAM. ***A complete system may be built with minimal additional parts other than a battery, speaker, microphone, and a few resistors and capacitors.***

Two ROM configurations of the RSC-4x are currently available. The RSC-4128 sports 128kb of ROM, and is recommended for all applications. In applications that require less duration of speech or smaller command sets, the RSC-464 is recommended for cost savings.

RSC-4128 Block Diagram

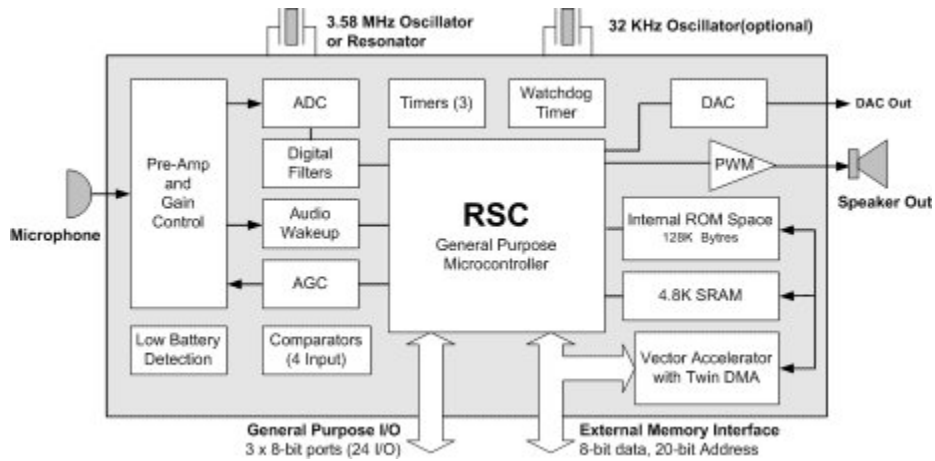

RSC-464 Block Diagram

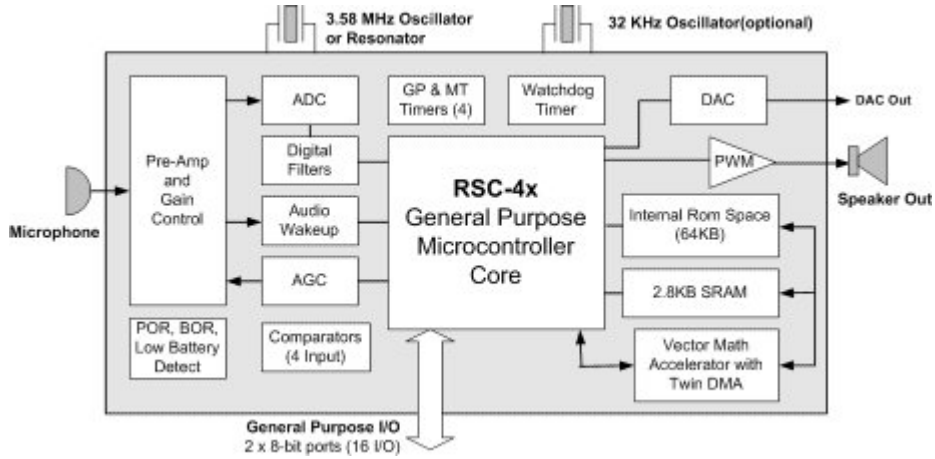

Also see the Interactive Speech **VR Stamp™** Voice Recognition Module on the Sensory webpage:

INTERACTIVE SPEECH™
VR STAMP™
 VOICE RECOGNITION MODULE

